

Accrete Industrial Mounting Solution (AIMS)

Designing Mounting Solution for Panel System

Mounting solution is a collection of different kinds of mounting methods that can help you to know how to mount your product correctly and rapidly. Mounting solution can also guide you to fine the product that really fit your needs.

Contents

Mounting Solution for PANEL/FLUSH MOUNT	01
Mounting Solution for IP65 Panel PC	04
Mounting Solution for Open frame Panel PC	06
Wall Mounting Solution	08
Rack Mounting Solution	10



Mounting Guide for PANEL / FLUSH MOUNT

Panel mount mechanism mount into an opening in a cabinet or enclosure from the front, and are secured from the rear. All user controls are located on the rear of the mechanism, making the panel mount displays a good choice for applications requiring a display with no external or exposed controls.



Panel /
Flush Mount

Overview-Panel PC

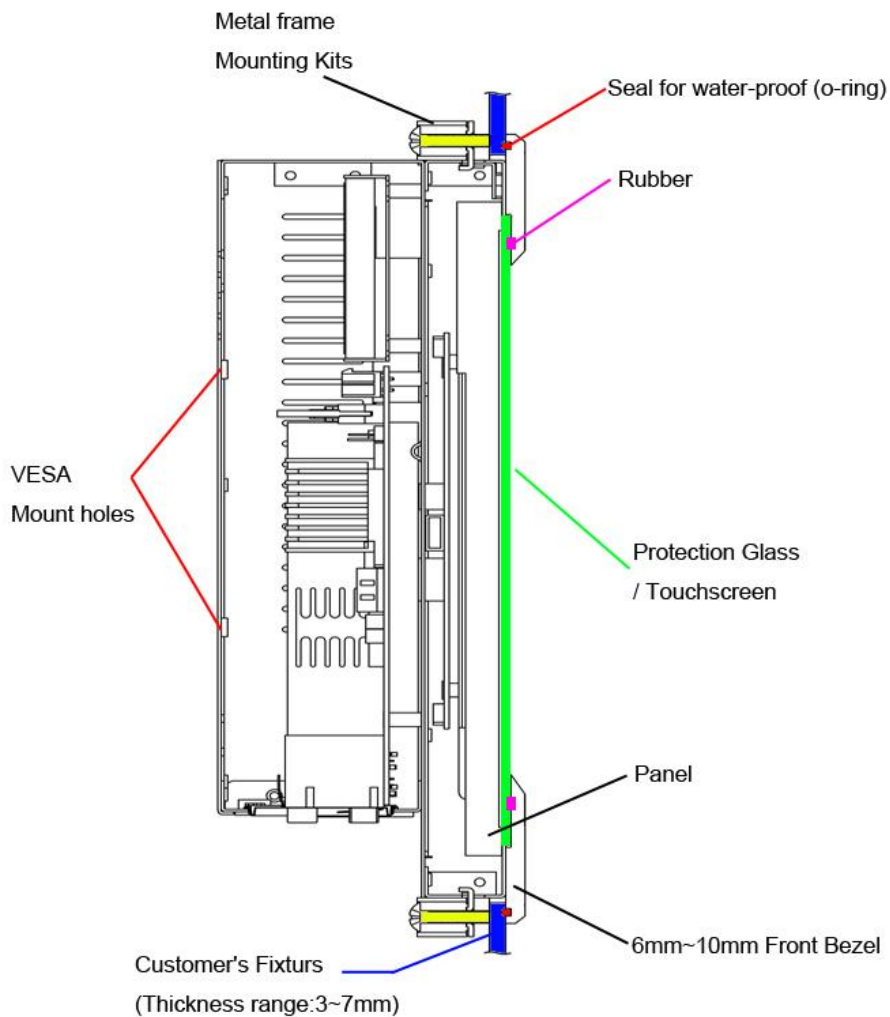

Accessories

A, Provide by ACCRETE

item	Content
1	Mounting Kits
2	Panel mount PPC

6-10mm Panel Mount Panel PC

-Customers can fix Panel PC with their fixture by M5 screws.

-VESA mount holes are also available for mounting from back side.

Panel pc PM 6-8mm	
Panel PC Size	Mounting Kits(pcs)
7"	4
8.4"	4
10.1"	6
10.4"	6
12.1"	6
15"	8
17"	8
19"	8

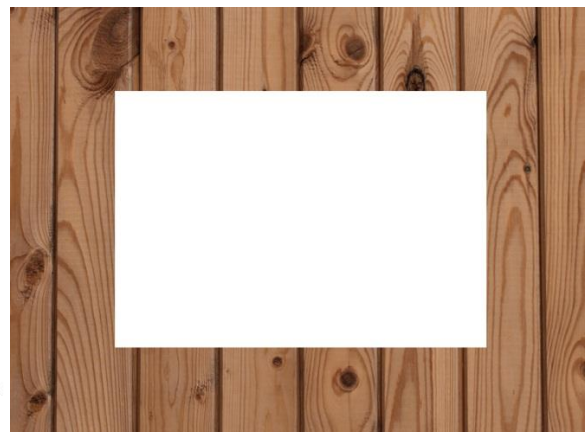
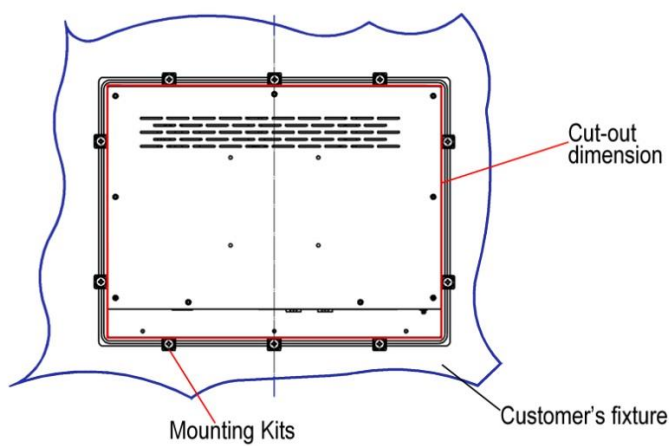

Installation Step & Application

STEP 1

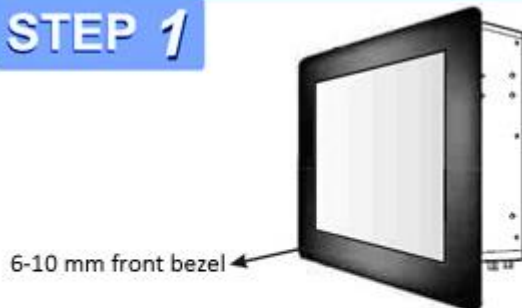

Panel Mount
(Front view)

STEP 2

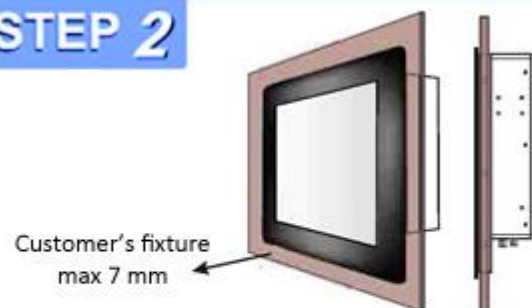

Put Panel PC on the fixture(wall,panel,...)
from the front,with the sides of
the front bezel shown on the outside

(Side View)

STEP 3

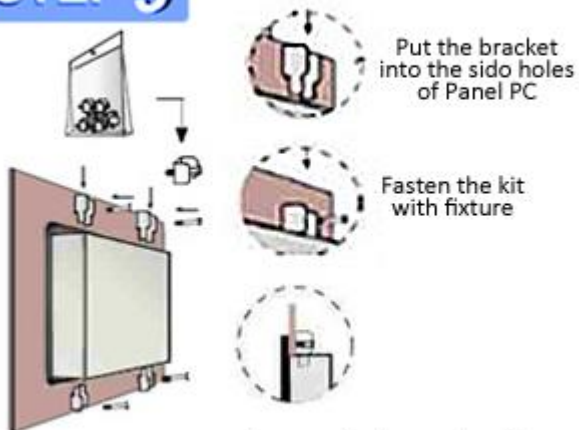

Use provided mounting kits
to fix the Panel PC and the
customer's fixture
(Rear View)

STEP 4

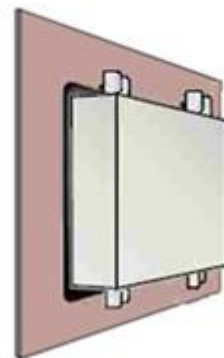

Finished



Mounting Solution for IP65(front)Panel PC

IP sealing is needed in various applications to make the products sealed against liquids, dust or humidity. With asda's special housing and mounting design, Asda's IP65 Panel PC can pass through the standard test procedure.

Overview-IP65 (Front) Panel PC

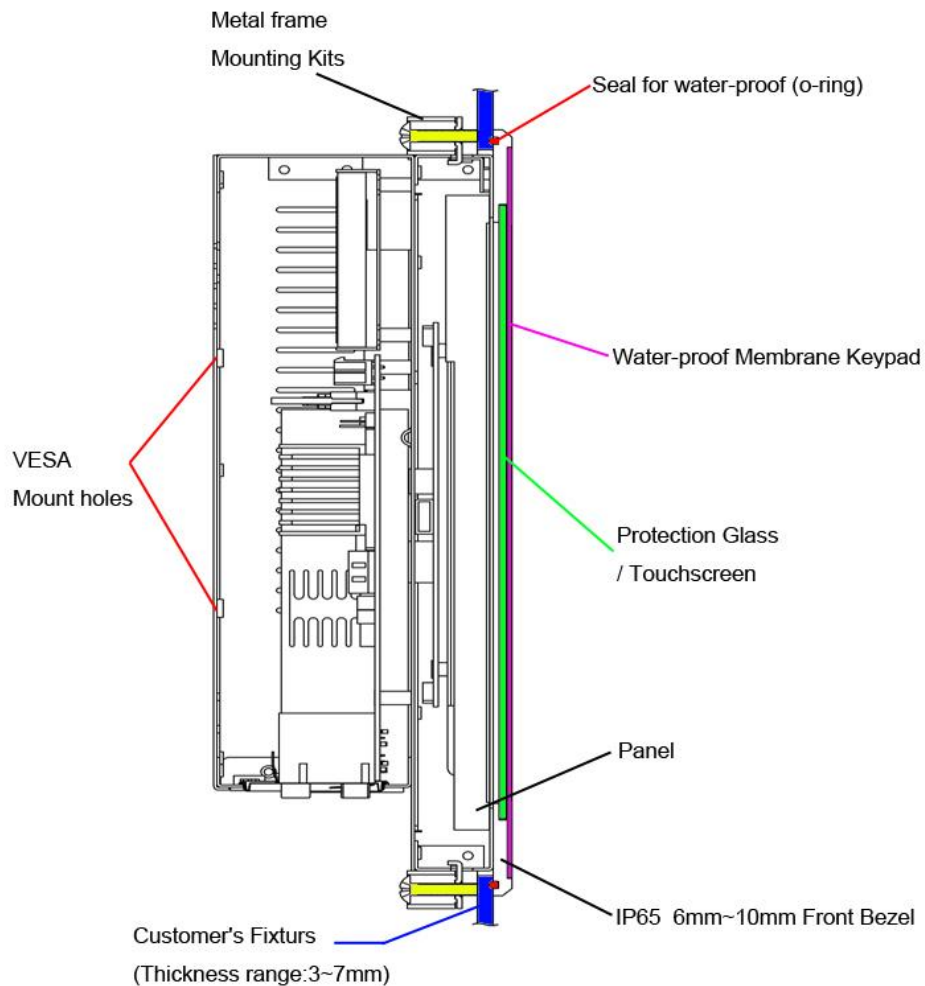



IP65(front) Panel PC has a special rubber (O-ring) on the rear of front bezel to seal front bezel and customer's fixture to prevent water and dust.





Mounting Solution for Open Frame Panel PC

ASDA office open frame Panel PC with a extremely versatile open-frame chassis that can be used for special mounting applications, especially in KIOSK and industrial PC area

Overview-Open Frame Panel PC

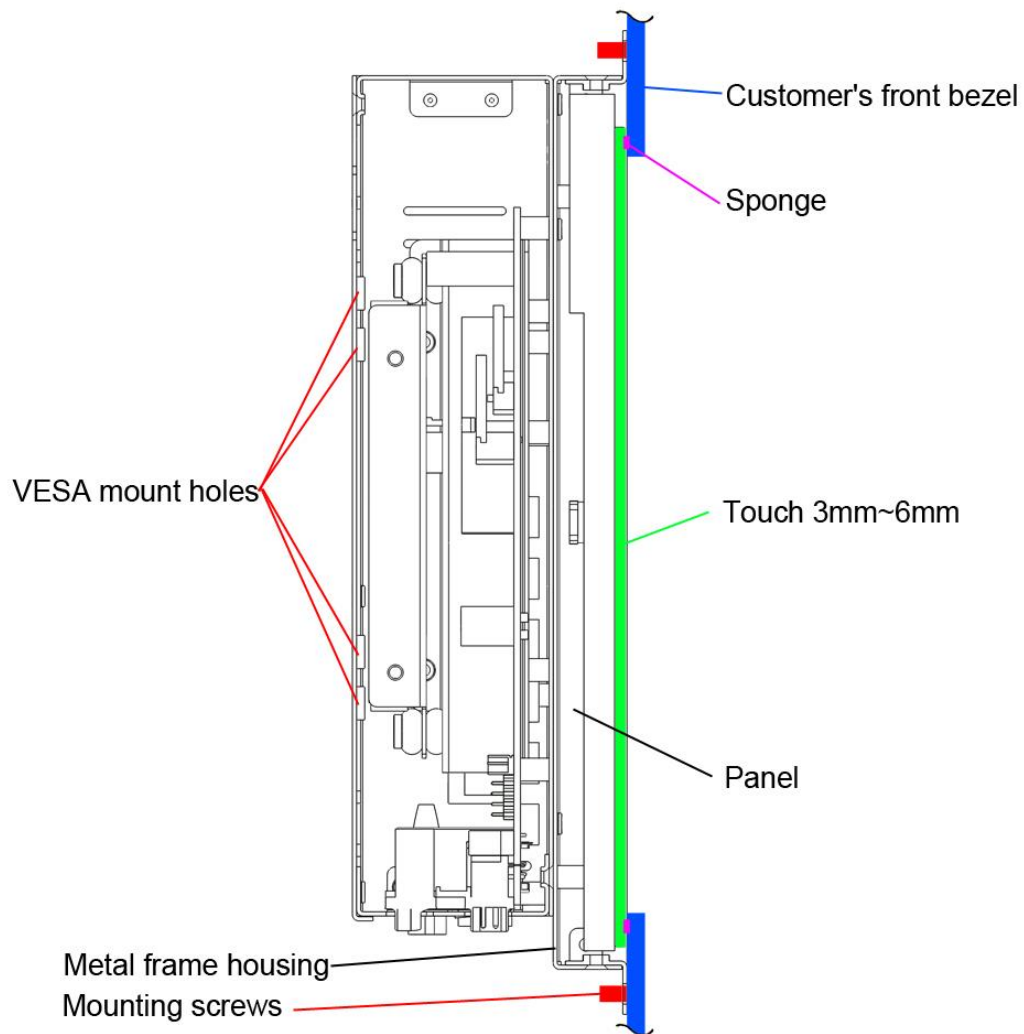

Installation Step & Application

Step1. Put panel PC on the fixture (Wall, panel.....)from the rear.

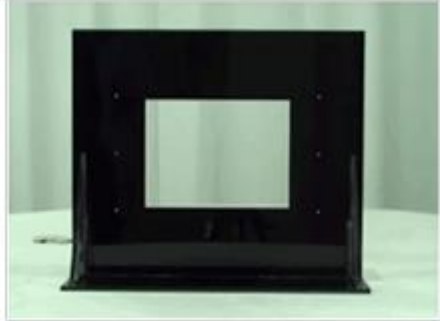

Customer's fixture Cut-out dimension and mounting hole base on drawing

Step 2.Fasten with M3 screw from the front of customer's fixture.



The length of M3 screws depend on the thickness of customer's fixture.



Front View



Side View



Wall Mounting Solution

Fast, simple wall mount, Meets VESA standards (75 x 75mm and 100 x 100mm), Loading 66 lbs. or 33kg, Includes screws and hardware kit.

Wall Mount Bracket

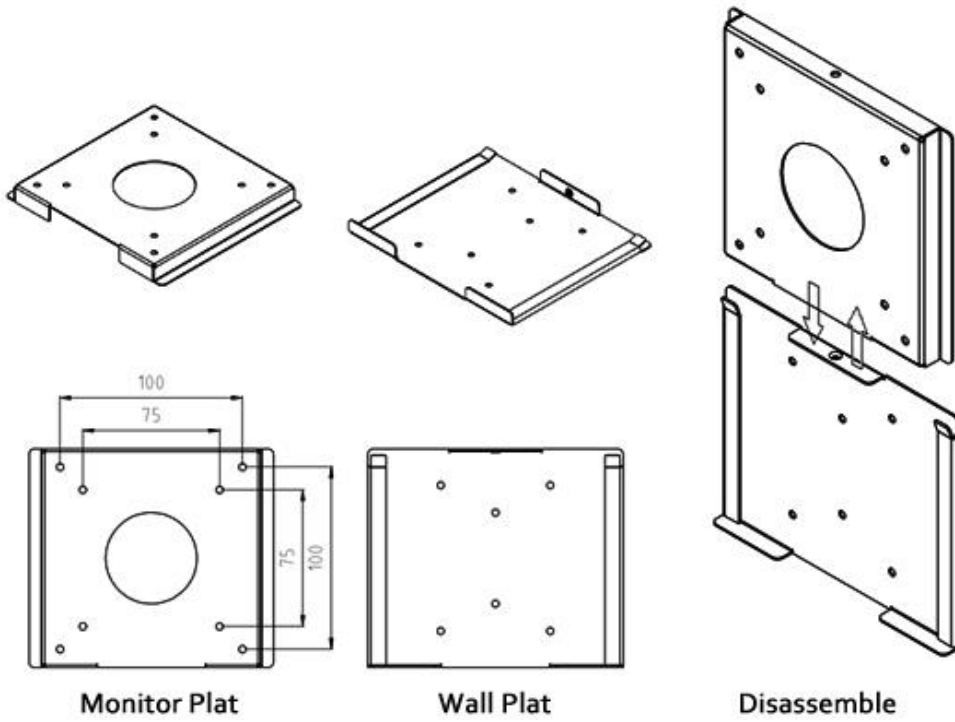

Use the wood screws, mount the wall plate to wall stud or use enclosed sheet rock mollies

Installation Step & Application

STEP 1

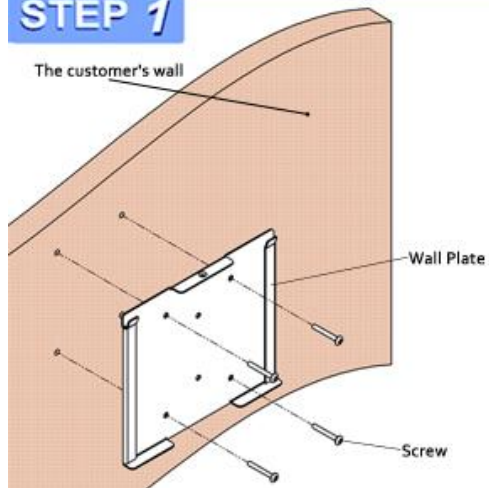

mount the wall plate to wall stud

STEP 2

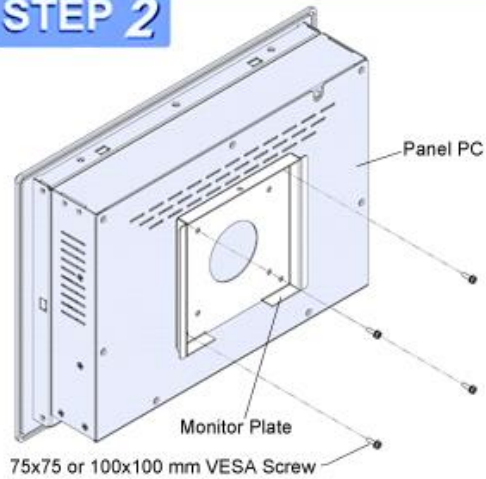

Depending on your Panel PC, use the 75mm or 100mm pre-drilled holes

STEP 3

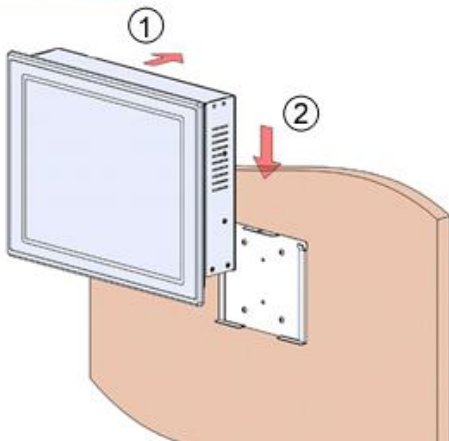

Simply slip your wall mounts



Rack Mounting Solution

rack mounting Where many computers are to be operated in close proximity, as with multiple server installations, the manufacturers of such processors may offer versions of their products, designed to be installed in standard 19" racking. Such products frequently support hot swap power supplies and disks to enhance reliability.

**Mount with rack front bezel
and then mounted into racks**

Step 1. Panel PC-assembled on the rack mounting kit

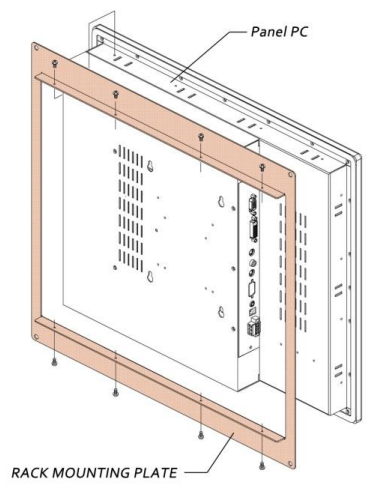

Step 2. Embedded in the customer's rack

